



Architects and
constructors
of musical
instruments

Experience the Sound of Quality

Manual

Revolution Timpani



Preface

Thank you for choosing Adams Revolution Timpani. We hope that you will gain pleasure and enjoyment from your new instrument, and we are confident that it will bring you many years of musical satisfaction. All Adams Musical Instruments are cleverly designed to the smallest detail, and are constructed with care and the highest levels of craftsmanship in Thorn, Holland.

Adams Revolution Timpani combine truly professional sound quality with innovative features for effortless portability. The groundbreaking balanced action pedal system allows the Revolution base to detach from the kettle without any tools, and retains the tension responsible for the fundamental tone in the base. When the kettle is separated from the base, the legs fold up for easy portability with the integrated handle. The fine tuner allows the drum not only precision tuning, but the gives the player the ability to select from over one octave of range. There has never before been a more practical, portable, and professional quality instrument.

In this manual, each feature is given brief description of how the feature works and a step-by-step adjustment guide. Understanding the adjustment is as important as making the adjustment.

At the factory, a new Remo Renaissance head is installed on all Adams timpani. During shipping and delivery, this head will stretch and settle. Before using your timpani for the first time, read and work through pages 4-9 to correct any mechanical difficulties caused by the change in the head tension. If necessary, general troubleshooting topics are available on page 21.

Adams Musical Instruments are the choice of world-class soloists, orchestras, educators, and composers because of the firm's continued dedication to producing the finest sounding instruments possible through innovation and superior craftsmanship. Andre Adams, the company's founder, began repairing brass instruments in 1971, and gained experience as an instrument maker with many well-known firms in Europe. Music was his hobby, engineering his passion. The importance of scientific innovation in establishing production quality and continuity, along with important relationships with top professional and amateur musicians, has led the company to emerge as one of the world's largest percussion instrument manufacturers. Adams' corporate vision is passion for music: creating instruments by musicians, for musicians. Experience Adams—Experience The Sound of Quality.

Contents

- 3 Nomenclature
- 4 Fundamental Tone
- 6 Pedal System
- 8 Tuning Gauge
- 10 Fine Tuner
- 12 Range Selector
- 13 Baroque Style Timpani
- 14 Detachable Kettle
- 16 Height Adjustment
- 18 Head Replacement
- 20 Clearing Heads
- 21 Troubleshooting
- 22 Use and Care
- 24 Specifications
- 25 Warranty
- 26 Accessories

Scan this QR code to check for the latest version of this manual, or visit: www.adams.nl/manuals/



Nomenclature

Revolution Timpani

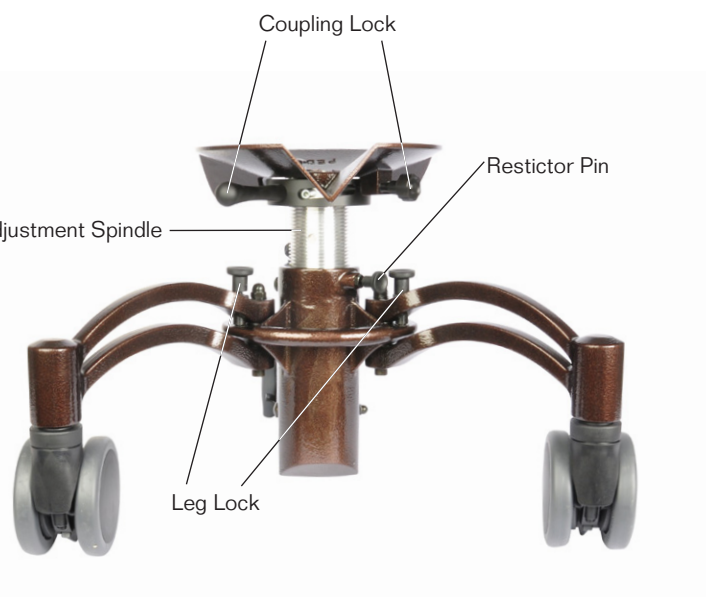
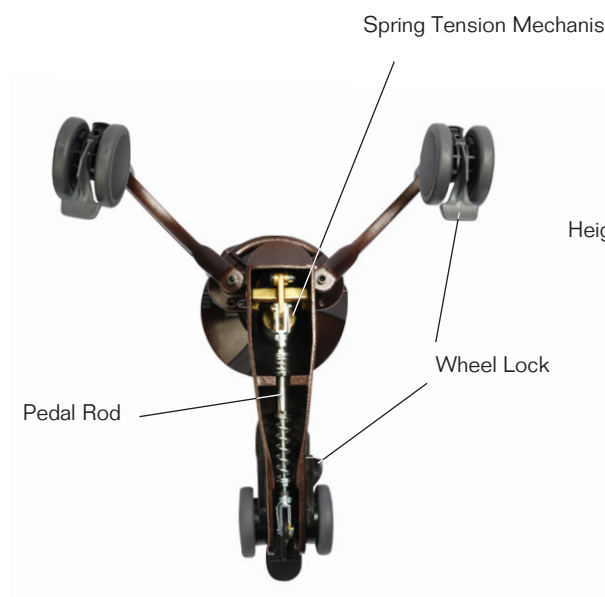

Fundamental Tone

Overview

Timpani are machines: mechanical parts work together to allow the player to change the tone of the instrument by means of a pedal, a fine tuner, or by both mechanisms. The pedal and fine tuner apply uniform tension to all of the tension rods at the same time.

Each timpani has a specific scalar range, and the lowest tone of this range is called the fundamental tone. The fundamental tone is set by the individual tension rods when the pedal is in the position of the lowest tone. The correct fundamental tones for Adams Revolution Timpani are listed below.

Fundamental Tone: Revolution Timpani

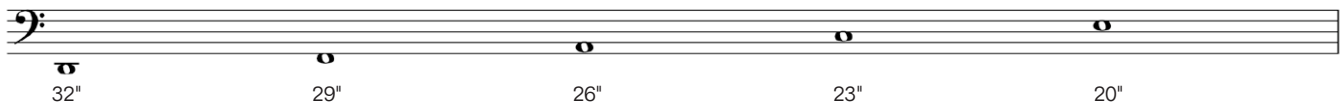

The pedal has a specific range of mechanical motion. Moving the pedal applies tension to the fundamental tone and produces the scalar range of each individual timpani.

Scalar Range: Revolution Timpani

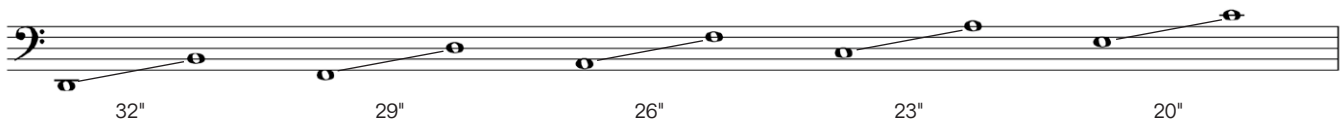

Adjustment

The head tension interacts with the mechanical balance. The correct fundamental tone is the most important factor in determining correct mechanical function. When the fundamental is correct, the pedal has a full range of mechanical motion, achieves the correct scalar range, and functions correctly. When the fundamental tone is too low or too high, the head tension will not work with the mechanical system: the pedal will not work correctly and the scalar range will be limited.

Revolution Timpani are available with a fine tuner. For models with a fine tuner, it is important to use the individual tension rods to tune the fundamental tone. Using the fine tuner to correct the fundamental will decrease the fine tuner function and affect the pedal feel.

Process

1
Move the pedal to the position of the lowest tone.



2
Models with fine tuner: Move the fine tuner to middle of its mechanical range. In this position, the white indicator will be in the middle of the channel.



See pages 10-11 for detailed information regarding fine tuner operation.

3
Confirm that the collar is even on each side of the kettle. Adjust as necessary.

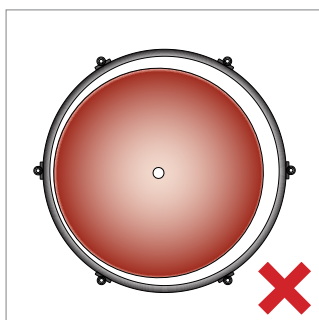
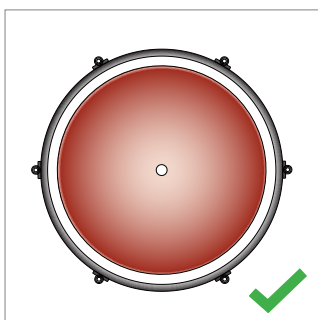

4
Use a tuning fork or other tuning device as a tone source. Play the fundamental tone and compare to the list on page 4.



5
If the tone is not correct, adjust to the correct fundamental tone.

- Make equal adjustments to each tension rod (half or quarter turns) in the order demonstrated in the picture.
- Evaluate the tone after each complete round of adjustment. Continue to adjust as necessary until the fundamental tone is correct.

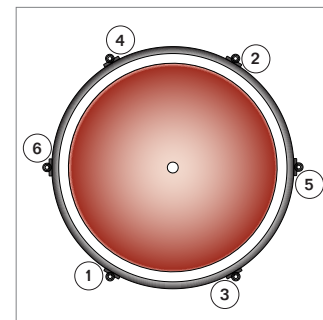

6
Maintenance

As a head stretches, the fundamental tone will become lower. The head will need to be adjusted according to the above process. Eventually, a plastic head can and will stretch to the point that it cannot provide the resistance necessary to balance the spring tension. The head will then need to be replaced to restore proper function.

Adams recommends changing heads once every two years to ensure correct mechanical function, or more often if the quality of the tone deteriorates.

Pedal System

Overview

The Revolution balanced action pedal system functions by balancing the tension of the head against the tension in a spring mechanism. These two forces push against each other and hold the pedal and tone in place. This strong yet simple system allows for accurate tuning.

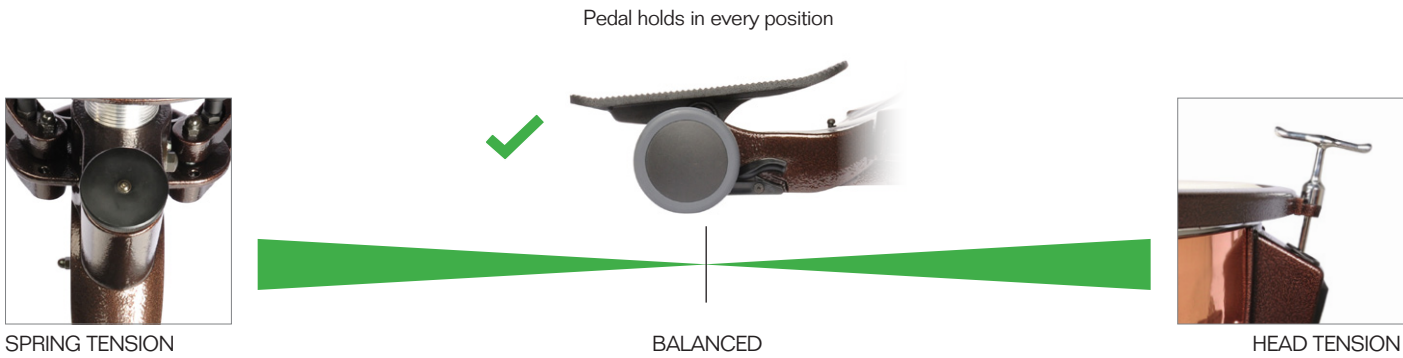

The balanced action pedal system functions correctly when the head tension and spring tension are in equilibrium. If the fundamental tone is not tensioned correctly, or the spring tension is too weak or strong compared to the correct fundamental tone, the pedal will not hold in place and the tone will change.

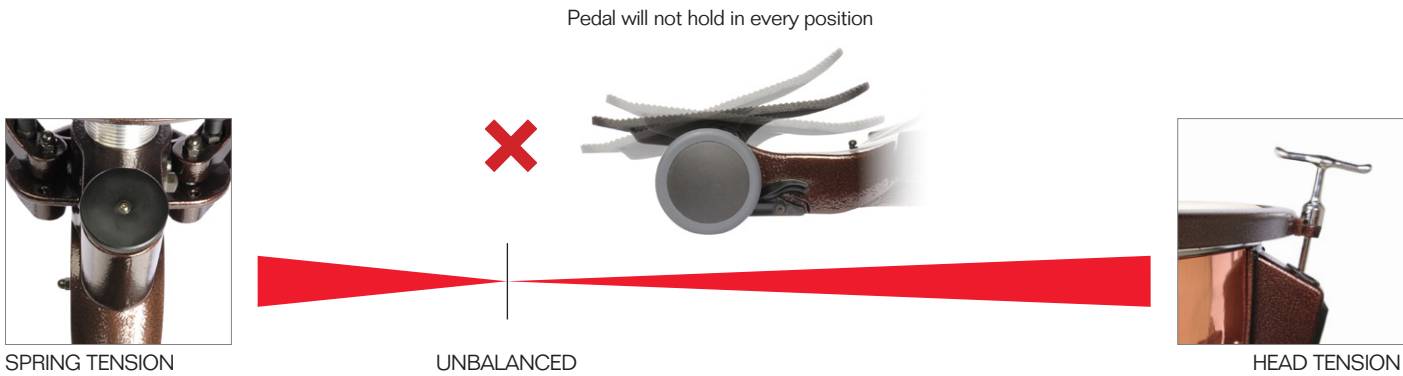

Adjustment

If the timpani pedal does not hold position, the fundamental tone or spring tension must be adjusted to restore correct pedal function. The usual source of the problem is that the fundamental tone has changed.

In general, the spring needs very little adjustment: due to the strength of the design, the spring can balance against a slightly incorrect fundamental without changing the pedal performance.

Process

1

If the pedal system is not functioning correctly, first confirm the correct fundamental tone as described on page 5.

- If the fundamental tone is correct, proceed to Step 2.
- If the tone is not correct, adjust to the correct fundamental tone as described on page 5.
 - If the pedal now holds position, the system is functioning correctly. Do not adjust the spring mechanism.
 - If the pedal continues to not hold position, proceed to Step 2.

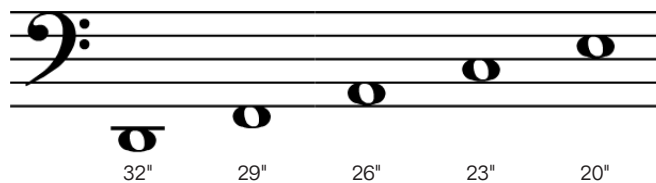

2

Correct the spring tension.

- If the pedal falls forward and raises the tone, turn the knob to the left. The spring mechanism needs less tension.
- If the pedal falls backward and lowers the tone, turn the knob to the right. The spring mechanism needs more tension.

⚠ Never adjust the spring tension without first confirming the correct fundamental tone.



Adjust the spring with the pedal in the position of the highest tone.



Always adjust the spring a half turn at a time, evaluate the adjustment, and adjust again if necessary.

3

Check the adjustment: Move the pedal and see if the function has changed.

- If the pedal performs as before, make the same adjustment again until the result is satisfactory.
- If the adjustment created the opposite problem (pedal was falling forward but is now falling backward), lessen the first adjustment until the result is satisfactory.

4

Maintenance

As a head stretches, the fundamental and/or spring tension will need to be adjusted according to the above process. A plastic head can and will stretch to the point that it cannot provide the resistance necessary to balance the spring tension. The head will then need to be replaced to restore proper function.

Adams recommends changing heads once every two years to ensure correct mechanical function, or more often if the quality of the tone deteriorates.

Tuning Gauge

Overview

A timpani gauge is a display of the pedal's mechanical position: it is not a measure of the tone that the instrument produces when played.



Adjustment

The pointer position, range of motion, and individual indice letters must all be adjusted for the tuning gauge to function correctly.

Process

1

Confirm the correct fundamental tone as described on page 5.

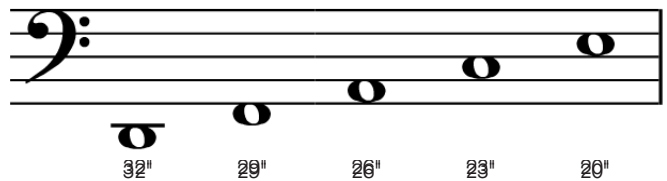

2

Set the distance of the pointer from the gauge.

- Move the pedal to the position of the lowest tone.
- Set the pointer to the desired distance from the gauge and the position of the lowest tone. Secure in place with the wing screw.

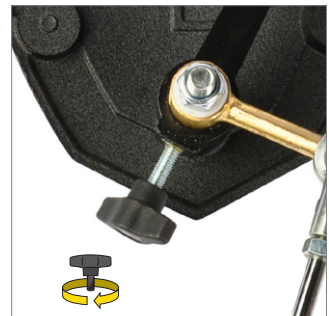
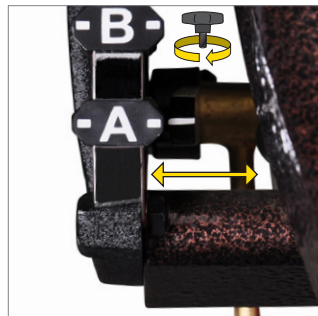

3

Set the range of motion.

- Move the pedal to the position of the lowest tone.
- Move the pedal through the scalar to view the distance that the pointer moves. Determine if more or less distance is necessary in the range in the motion.
 - For more distance, move the fitting towards the axel.
 - For less distance, move the fitting toward the tip.

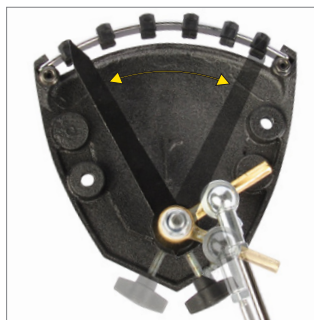

4

Adjust the letters: set all similar tones (identical and octaves) before moving to another tone. Begin with **A2**.

- 4.1 Tune **A2** on the 29" timpani. *Set the 29" A indice.*
- 4.2 Tune **A2** on the 26" timpani and match it to the 29".
Set the 26" A indice.
- 4.3 Tune **A3** on the 23" timpani, one octave higher than **A2**. Begin with the tone source, and tune with the octave **A2** on the 29".
Set the 23" A indice.
- 4.4 Tune **A3** on the 20" timpani, and match it to the 23".
Set the 20" A indice.
- 4.5 Repeat steps 4.1-4.5 with B, C, D, E, F, G: match identical tones and octaves.



Use a tuning fork or other tuning device as a tone source.

5

Maintenance

A head will stretch over time, lowering the fundamental tone. The tuning gauge will become inaccurate when this happens. Restore correct tuning gauge function by correcting the fundamental tone of the head as described on page 5.

If moving the letters is required after correcting the fundamental tone, the letters will usually end up with very little space between the letters as demonstrated in the incorrect picture. When this happens, the head has stretched to the point that it needs to be replaced.

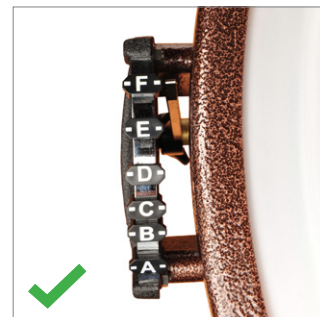

Fine Tuner

Overview

A timpani pedal applies pressure to all of the tension rods at the same time. The fine tuner does the same thing in smaller and more precise increments, giving the player precise intonation control.

Fine tuner mechanisms are usually only available on timpani with a clutch mechanism. Adams has made the fine tuner available as an option on Revolution Timpani. The fine tuner can only be included on new instruments from the factory, and it is not available as an accessory for installation on models without a fine tuner.

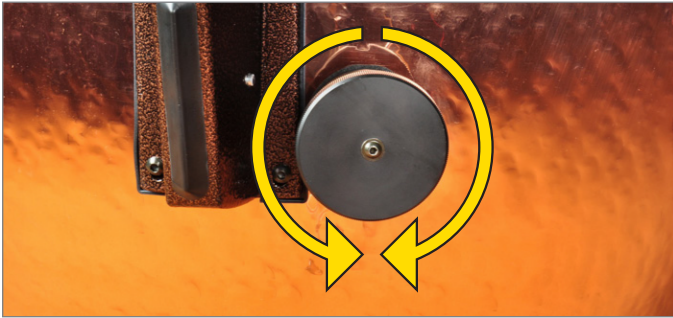

Like the pedal mechanism, the fine tuner has a mechanical range of motion. For correct function, the fine tuner must be positioned near the middle of its mechanical range. This position allows the player to either raise or lower the tone. When the fine tuner is in either the highest or lowest mechanical position, the fine tuner will not have full function: the player will not be able to both raise and lower the tone. The fine tuner system includes an indicator for clear view of the mechanical position.



Adjustment

Timpani with fine tuners have two mechanisms that set the fundamental tone: the tension rods and the fine tuner. The relative amount of tension applied by each of these mechanisms determines the amount of resistance in the pedal motion. If these two factors are out of balance, the resistance in the pedal feeling is affected and the fine tuner will not have full functionality.

Process

1

If too much tension is applied by the fine tuner compared to the tension rods, the pedal resistance is high. This occurs when the fine tuner is in the highest mechanical position. In this position, the player can only use the fine tuner to lower the tone.

- Move the fine tuner to the middle of the range.
- The fundamental tone must now be tuned higher. Correct the fundamental tone with the tension rods as described on page 5.

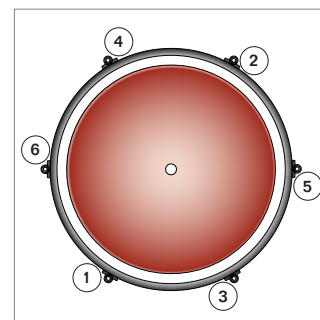
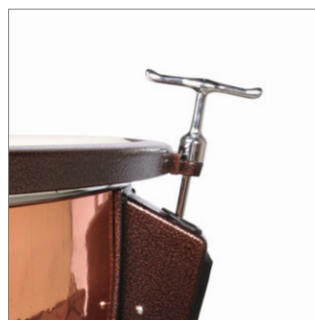

2

If too little tension is applied by the fine tuner when compared to the tension rods, the pedal resistance is low. This occurs when the fine tuner is in the lowest mechanical position. In this position, the player can only use the fine tuner to raise the tone.

- Move the fine tuner to the middle of the range.
- The fundamental tone must now be tuned lower. Correct the fundamental tone with the tension rods as described on page 5.

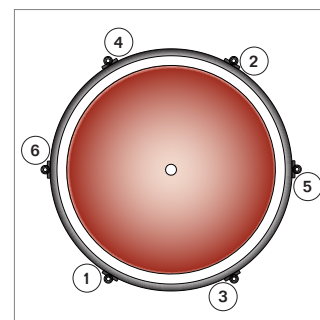

3

Check the pedal performance. If necessary, adjust as described on page 7.

4

Maintenance

As the head stretches, it is important to correct the fundamental tone with the tension rods. It is faster to make this adjustment with the fine tuner, but doing this will eventually move the fine tuner to the end of its mechanical range and negatively affect pedal performance.

Range Selector

Revolution Timpani have a mechanical range that produces a scalar range of a musical 6th (see diagram on page 4). Revolution timpani with optional fine tuner can easily select a fundamental tone that is either lower or higher than normal. Changing the fundamental tone allows the player to select a range of a 6th from within an octave of tonal range.

Example:

A 29" with a F2 fundamental tone has a range from F2-D3.

- Adjusting the fundamental tone higher to G2 produces a range from G2-E3
- Adjusting the fundamental tone lower to E2 produces a range from E2-C3
- The total available range to select from is an octave, E2-E3.

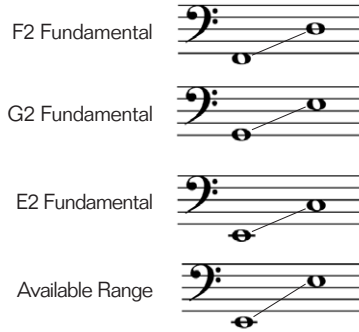

In addition to giving each size a larger range to choose from, the range selector can also increase the overlap in ranges between sizes. This larger overlap can allow a player to not bring a specific size to a gig. For example, if a 23" timpani is only needed for a G3 tone, the 26" range can move from A2-F3 to B2-G3 to play the G3 if the music allows.

Adjusting the fundamental does change the balance between the spring tension and the head tension. However, the strong design of Adams' spring tension mechanism will usually accommodate a small change to the fundamental without the head tension affecting the pedal position. Always evaluate the pedal performance after adjusting the fundamental.

Process

- 1 Move the pedal to the lowest tone.
- 2 Use the fine tuner to select the new fundamental tone.
- 3 Adjust spring tension if necessary (see page 7).

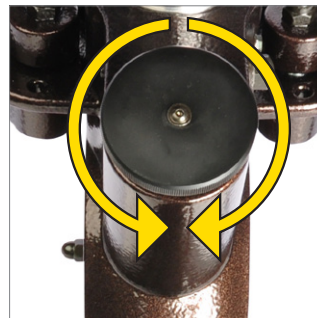
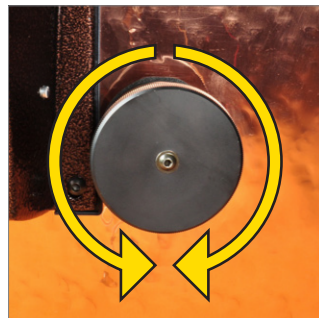

- 4 Changing the fundamental will change the accuracy of the tuning gauge.

- If the adjusted fundamental is necessary for an extended period of time, reset the letters of the gauge.
- If the adjusted fundamental is necessary for a short period of time, make changes to the gauge letters as necessary.

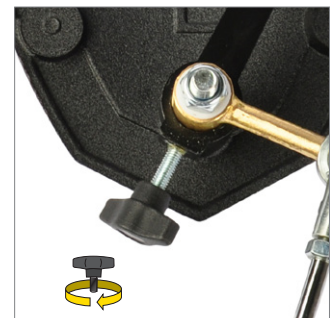
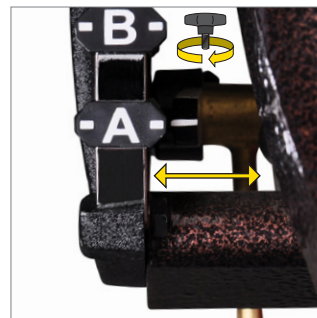

Baroque Style Timpani

The tension responsible for the Revolution Series fundamental tone is held in the mechanism in the kettle. Because of this design, the Revolution kettle can be removed from the base and placed on a wooden stand for use as Baroque style timpani. The fine tuner knob is then used as the tensioning mechanism.

Process

1

Note the position of the fine tuner indicator. It is necessary to return the fine tuner to this position before returning the kettle to the base. The indicator does not have to be in the middle of the mechanical range, but the middle will give the player the best functionality.



2

Remove kettle from base as described on page 14.

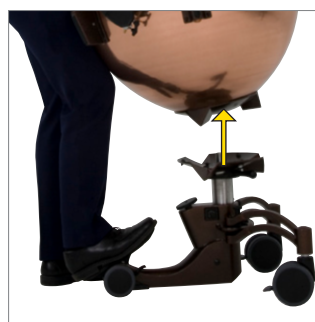

3

Place on wooden stand for use as Baroque timpani.

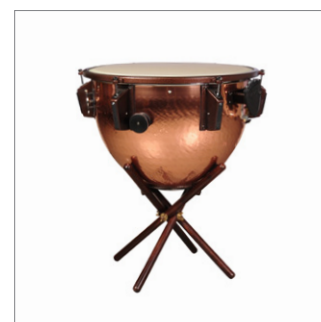

4

Before returning to the base, return fine tuner position to position from step #2.



5

Install kettle on base as described on page 15.

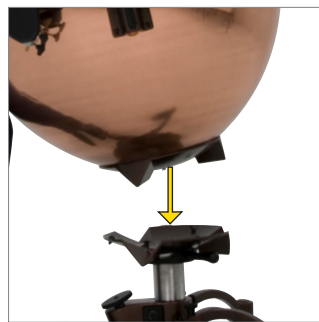

6

Confirm fundamental tone, as it can be different after using the fine tuner as the tensioning mechanism. Adjust the fundamental tone as necessary with fine tuner instead of the tension rods because the fine tuner was used as the tensioning mechanism during Baroque style use.

Features

Detachable Kettle

Adams Revolution Timpani are the ultimate in portability and functionality. The kettle quickly and easily detaches from the folding base for effortless transport.

Process - Removal of kettle from base

1

Lock all wheels.



2

Unlock the coupling mechanism: Loosen the screw and then turn the handle.

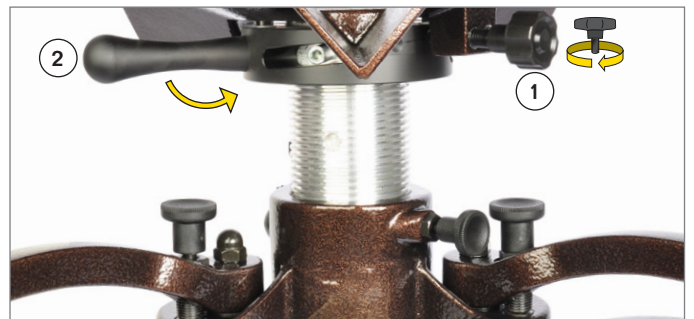

3

Move the pedal to lowest tone and then a little more past a slight resistance. The resistance is the locking mechanism releasing the kettle from the base.

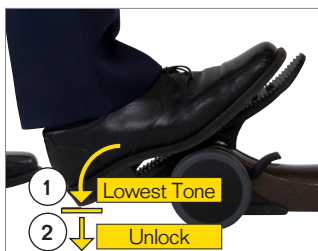

4

Hold the pedal down and lift the kettle from the base. After the kettle is removed, use your foot to move the pedal to the highest position. Never move the pedal with your hand.

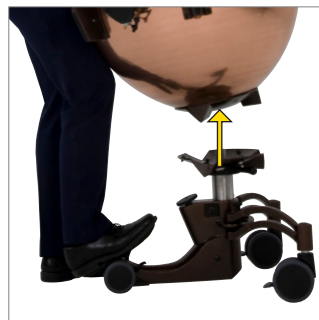

5

A plate protects the bottom of the kettle. The kettle may be safely placed on the floor before being secured in a soft gig bag for transport.

6

Lift the pins on the legs and fold the legs into locked position. Transport the base either by carrying with the integrated handle or with the wheeled gig bag.



Process - Installation of kettle onto base

1
Unfold the base legs and lock into position. Make sure that all wheels are locked.



2
Make sure that the coupling mechanism is unlocked: Loosen screw, turn handle.

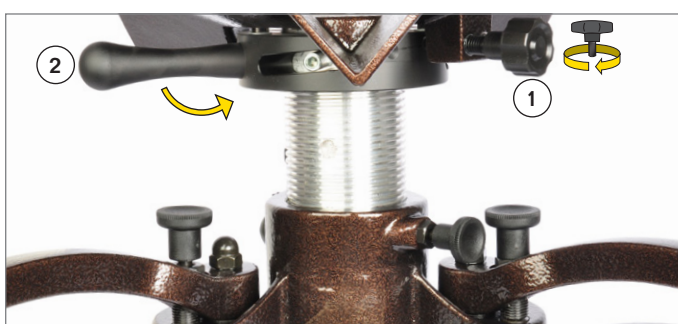

3
Make sure that the pedal is in the position of the highest tone.
Never move the pedal with your hand.

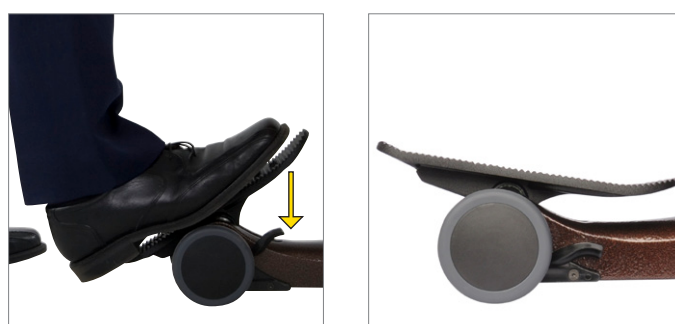

4
PEDAL on the receiving plate must align with the pedal.

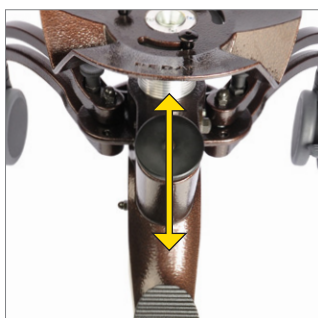

5
Install the kettle onto the base. Position logo on the head opposite of the pedal.

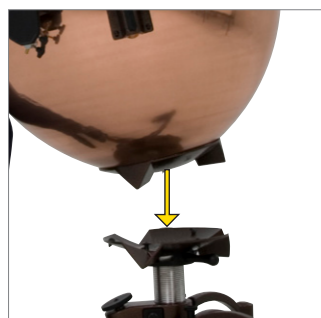

6
Move the pedal to the lowest tone, and then a little more past a slight resistance. The resistance is the locking mechanism joining the kettle with the base.



7
Lock the coupling mechanism: Turn the handle and then tighten the screw



Height Adjustment

Adams Revolution Timpani feature a patented height adjustment system. The kettle is supported on a spindle that provides height adjustment. The spindle is unlocked and locked with the included timpani tension key. The system includes a restrictor pin that prevents the spindle from rotating out of the base.

Process

1

Lock all wheels.



2

Loosen locking bolt with tuning key.



3

Rotate the kettle to the left to raise the height, and rotate the kettle to the right to lower the height.



4

The restrictor pin will prevent the spindle from rotating out of the base. It does not require adjustment. Do not remove the restrictor pin from the base.



5

Position the tuning gauge in the appropriate playing position.



6

Use tuning key to tighten locking bolt.





Head Replacement

Overview

Adams recommends changing heads once every two years to ensure correct mechanical function, or more often if the quality of the tone deteriorates.

Timpani head sizes are not the same as the size of the kettle. Head sizes are equal to the size of the kettle added to the total size of the collar. Refer to the chart below for the correct head sizes for Adams Revolution Timpani.

TIMPANI SIZE	32"	29"	26"	23"	20"
HEAD SIZE	34" Remo Size: 3400	31" Remo Size: 3100	28" Remo Size: 2800	25" Remo Size: 2500	22" Remo Size: 2200

Process

1
Lock all wheels.



2
Models with fine tuner: Move fine tuner to middle of its mechanical range. The white indicator will be in the middle of the channel.



3
Move the pedal to the lowest tone. Block the pedal with a piece of wood.

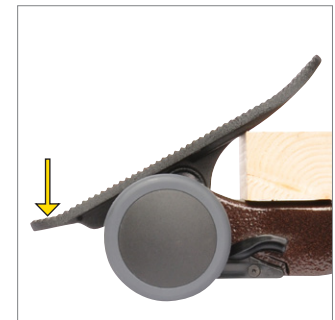

4
Remove tension rods.

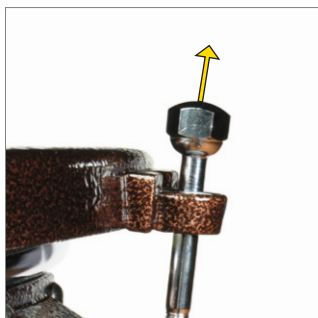

5
Remove counter hoop and head. Clear any dust or debris that may have accumulated under the counter hoop.



6
Head installation is an excellent time for routine maintenance. Please see the "Cleaning and Lubrication" sections of "Use and Care" on pages 22-23 for recommended maintenance during head installation.

7

Tension rods are connected in pairs to the central tension mechanism. For correct function, the tension arm brackets must be perpendicular to the mechanism. Confirm that each is correct before installing the head. Uneven position will prohibit smooth pedal operation.

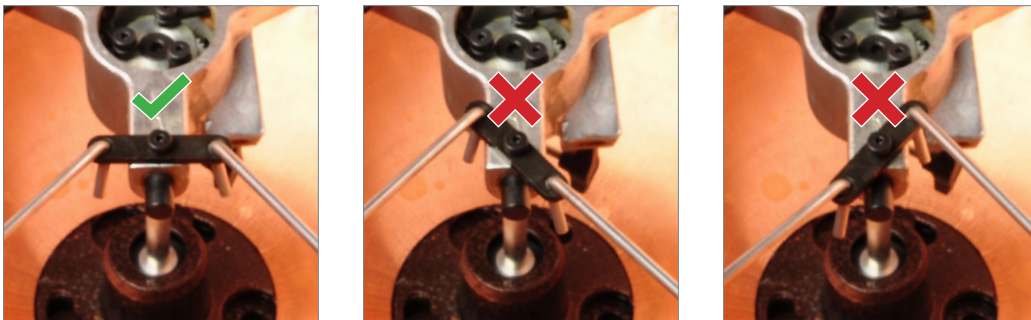

8

Place a new head on the kettle with the logo opposite the pedal. Start each tension rod with only 1-2 turns.

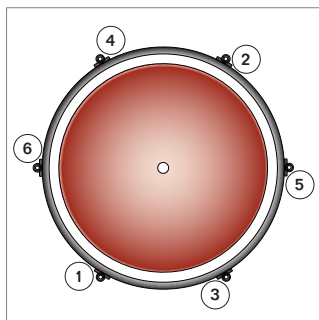

9

Center head on kettle. Confirm even collar on each side of the kettle.

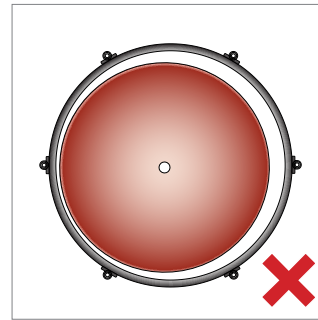
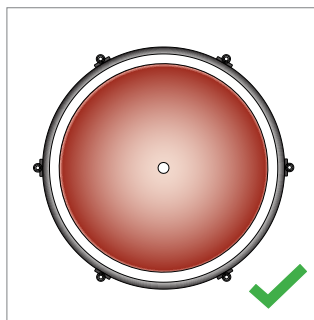

10

Check the centering of each pair of tension rods. The position of each pair can be felt and controlled underneath the tension rod bracket.

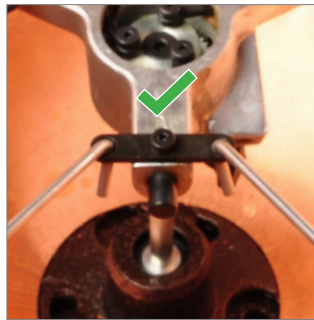

11

Apply initial tension to the head. Engage each tension rod to the point where it just begins to apply pressure to the head. Use the tension pattern in the picture when adjusting the tension rods.

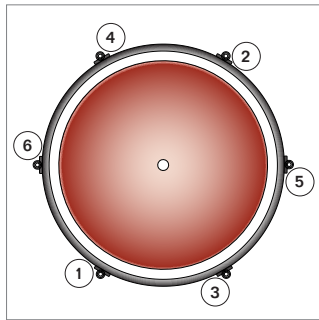

12

Use the tension rods to tune the fundamental tone as described on page 5. When fundamental is correct, remove block from pedal. Do not place fingers underneath pedal.

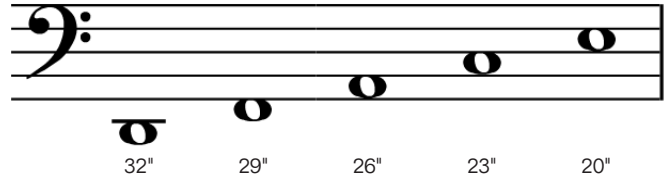

13

Correct pedal spring tension as necessary (see page 6).

14

Place pedal in the position of the highest tone. Keep the pedal in this position for 48 hours. The head will stretch during this time. Afterwards, correct the fundamental tone with the tension rods and adjust the spring tension as necessary.

15

Set the tuning gauge as described on pages 8-9.

16

After the head has stretched, unevenness in the tone may be cleared if necessary.

Clearing Heads

Overview

"Clearing heads" refers to the process of accurately tensioning each tension rod to achieve a perfectly clear tone.

Do not use an electronic tuner to attempt to get each tension rod in tune. An electronic tuner will pick up all the tones occurring in the head, and it is not able to isolate the sound coming from each individual tension rod. Using a tuner on each individual tension rod is like trying to tune one harp string while strumming all the strings at once. The only way to isolate the sound coming from each individual tension rod is by using the human ear.

Adjustment

Head clearing must be done in a quiet environment and only for ten minutes at a time. The ear fatigues quickly: attempts to work for long periods of time will produce incorrect results. Make one or two small adjustments that are absolutely correct and continue again at a later time. There are many ways to clear timpani heads. Below is the most basic process.

Process

1

Tune the head to a tone in the middle of the range. Place an Adams timpani mute in the center of the head.

2

Put your ear against the counter hoop and play the head two inches in front of a tension rod with a very hard stick and soft stroke. Play three quick strokes and listen to the tone at a tension rod. Move to the two adjacent rods and repeat. Focus only on the lowest fundamental tone you can hear: do not listen to any high harmonics.

3

Make note of the tension rod that sounds extremely flat or sharp and focus on it first. Raise or lower the tone of that tension rod by one quarter turn accordingly until the tone more closely matches the tone of the tension rod to the immediate right and left. Focusing on one tension rod and its two adjacent tension rods at a low volume is best.

4

Repeat step #3 and work around the head in a clockwise motion. With effort, the heads can be cleared from inconsistencies.

Troubleshooting

During normal use, all timpani require need minor adjustments to maintain correct working order.

As discussed in previous sections, the correct fundamental tone is the most important factor in maintaining excellent working order. Because a head naturally stretches, regularly checking the fundamental tone and correcting as necessary is highly recommended. Almost all troubleshooting begins with correcting the fundamental tone.

HEAD/PEDAL	Refer to Pages
Symptom: The fundamental note gradually becomes lower over time. Diagnosis: All heads stretch, slowly lowering the fundamental tone. Action: First set the fundamental tone, then adjust the spring tension if necessary.	4-5 6-7
Symptom: The pedal does not hold in every position. Diagnosis: Either the fundamental or spring tension is incorrect. Action: First set the fundamental tone, then adjust the spring tension if necessary. If these actions do not correct the problem, change the head.	4-5 6-7 10-11 18-20
Symptom: The timpani does not achieve the correct scalar range. Diagnosis: The fundamental or spring tension is incorrect, or the head needs to be replaced. Action: First set the fundamental tone, then adjust the spring tension if necessary. If these actions do not correct the problem, change the head.	4-5 6-7 18-20
Symptom: The quality of the tone produced has decreased. Diagnosis: The head is played out: denting in the head is probably visible when the timpani is tuned to the lowest tone. Action: Change the head.	18-20
Symptom: The head is not centered. Diagnosis: The collar is uneven. Action: Loosen tension in head, move collar, check tension mechanism in strut, and retune fundamental tone.	4-5 18-19
Symptom: There is noise coming from the head when the pedal is moved. Diagnosis: The kettle bearing edge is not correctly lubricated. Action: Remove the head, remove old lubrication, and apply new lubrication.	22

TUNING GAUGE	Refer to Pages
Symptom: The tuning gauge indicator only moves a small distance. Diagnosis: The tuning gauge connection rod position on the axel is incorrect. Action: Adjust the position of the connection.	8-9
Symptom: The tuning gauge letters are not accurate. Diagnosis: Either the tuning gauge letters need to be set or the fundamental tone has lowered. Action: First correct the fundamental tone, then move the letters if necessary.	8-9
Symptom: The tuning gauge indicator does not move when the pedal moves. Diagnosis: Either the indicator or the connection rod is loose. Action: Find the loose connection and tighten as necessary.	8-9

FINE TUNER	Refer to Pages
Symptom: The pedal resistance is either very high or very low. Diagnosis: The fine tuner is at an extreme in its mechanical range. Action: Move fine tuner to middle of mechanical range and retune fundamental with tension rods.	10-11
Symptom: The fine tuner is not responsive. Diagnosis: The fine tuner is at an extreme of its mechanical range. Action: Move fine tuner to middle of mechanical range and retune fundamental with tension rods.	10-11

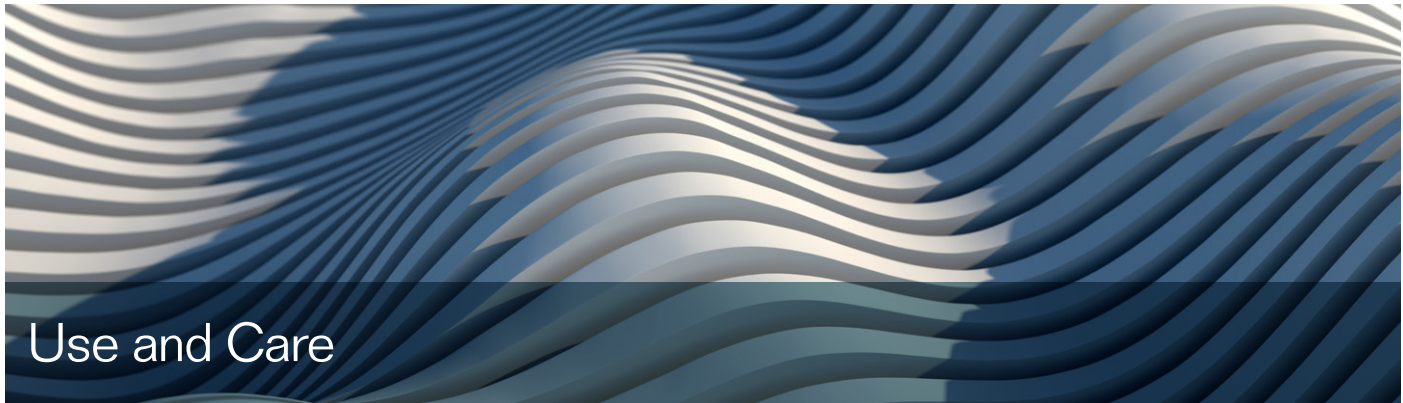

Use and Care

Overview

Timpani require routine care and maintenance. The small amount of necessary maintenance does not require a technician and can be a do-it-yourself project for any percussionist or band director.

Moving and Transport

1. Adams Revolution Timpani feature integrated wheels for effortless moving. Always lock all wheels when the timpani are in use. The locks secure the timpani in place while the pedals are used. Always unlock all wheels before moving the instrument. Moving the instrument with the locks engaged will damage the wheel.
2. When lifting the timpani is necessary, including on stairs, sloped, or uneven surfaces, always lift the timpani by the tension brackets with two people.
3. Never lift or push the instrument by the counter hoop, as this can cause the collar to become uneven and deform the head and counter hoop. Always push or lift by the tension brackets.
4. When moving the timpani by vehicle, either contain the instrument in a gig bag/flight case or secure in place with strapping material. Do not lay the instrument on its side, as this can damage the struts, support ring, counter hoop, head, and kettle. Horizontal transport can cause the kettle to become out of round and will definitely cause the collar to become uneven.

General Care

1. Move the pedal to the lowest tone position after each use. If the fundamental is tuned correctly, the collar will not shift during normal transport.
2. Use a drop cover to protect from dust and use a head cover to protect the head from damage.
3. Avoid running the timpani into objects—walls, other instruments, etc. In addition to potential damage to the instrument, the collar may become uneven.
4. Clean frame with a soft cloth and general purpose cleaner.
5. Clean kettle only as necessary: Only use a slightly wet, soft cotton cloth to remove debris. Using any type of glass cleaner or abrasive cleaner will remove the lacquer and cause discoloration to the kettle.
6. Polish chrome: Use a soft polishing cloth and polishing cream to clean and polish chrome parts.

Cleaning and Lubrication

1

Kettle bearing edge

Remove old lubrication with either #0000 steel wool or fine emery cloth.

Remove any debris with a clean, lint free cloth.

Apply new Teflon lubrication according to manufacturer's directions. Apply multiple layers of spray, allowing each layer to dry in between applications. Never use grease on the lip of the kettle. Grease on the head is bad for the sound of the instrument.

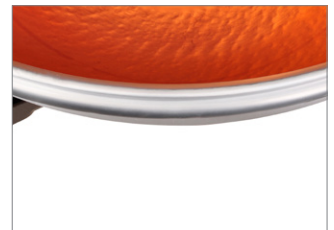

2
Tension rods

Remove old grease with mild cleaning agent on a soft cloth or #00 steel wool.



Remove cleaning agent with a slightly wet soft cloth.



Replace tension rod washer if necessary. (Washer part number PB418, quantity 1 each)



Apply small amount of multi-purpose lithium grease to tip of tension rod.

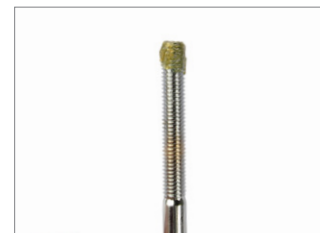

3
Tensioning mechanism: Use aerosolized lithium grease (not oil, WD40, or similar products) to direct lubrication into the following places as necessary. Always use a cloth to protect the instrument from overspray.

Axel pin in struts



Tuning Gauge Connection Rod



Pedal Axel



Pedal Connection Rod



Fine tuner mechanism (if applicable)



Spider

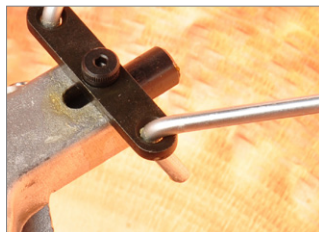

Spring Tension Mechanism

⚠ DO NOT DISASSEMBLE THE SPRING TENSION MECHANISM.

The spring mechanism has been lubricated at the factory with a long lasting, high performance grease.

Disassembly will only cause problems that are not easily solved.

4
Tuning gauge mechanism: Use aerosolized lithium grease (not oil, WD40, or similar products) to direct lubrication into the following places as necessary. Always use a cloth to protect the instrument from overspray.

Linkage Joint



Indicator Axel



5
Replace head centering insulation as necessary. The foam insulation pieces center the head in the counterhoop, making it easier to have an even collar.

Insulation for 20/23/26: PT012
Insulation for 29/32: PT013

(Each part number is 1 piece of foam)



Specifications

Adams Revolution Timpani
 PEDAL STYLE: Balanced Action
 CONFIGURATIONS: American and German
 TUNING GAUGE: Standard
 FINE TUNER: Optional
 KETTLE TYPES:

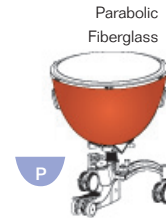
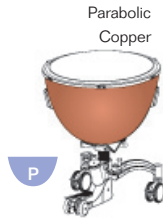

	32"	29"	26"	23"	20"
HEIGHT 	84 cm	84 cm	84 cm	84 cm	84 cm
LENGTH 	93 cm	87 cm	84 cm	79 cm	76 cm
WIDTH 	95 cm	87 cm	82 cm	72 cm	67 cm
RANGE	D2-B2	F2-D3	A2-F3	C3-A3	E3-C4
HEAD TYPE	Remo Renaissance -- Hazy Film with Aluminum Insert Ring				
HEAD SIZE	34" Remo Size: 3400	31" Remo Size: 3100	28" Remo Size: 2800	25" Remo Size: 2500	22" Remo Size: 2200

Specifications subject to change without notice

Warranty

Adams Musical Instruments is pleased to guarantee all Percussion Instrument for a period of one year from the original purchase date from your authorized Adams dealer.

This warranty specifically excludes:

- Wear from normal use
- Damage from neglect, abuse, accident, or improper maintenance
- Exposure to extremes in temperate or humidity
- Heads, Mallets, and Keyboard Bars

Adams Musical Instruments reserves the right to determine whether the asserted defects were caused by the above mentioned conditions or not. Please contact the authorized Adams dealer from which your instrument was originally purchased for warranty service. Warranty coverage may vary from country to country; please contact your dealer/distributor for relevant details.



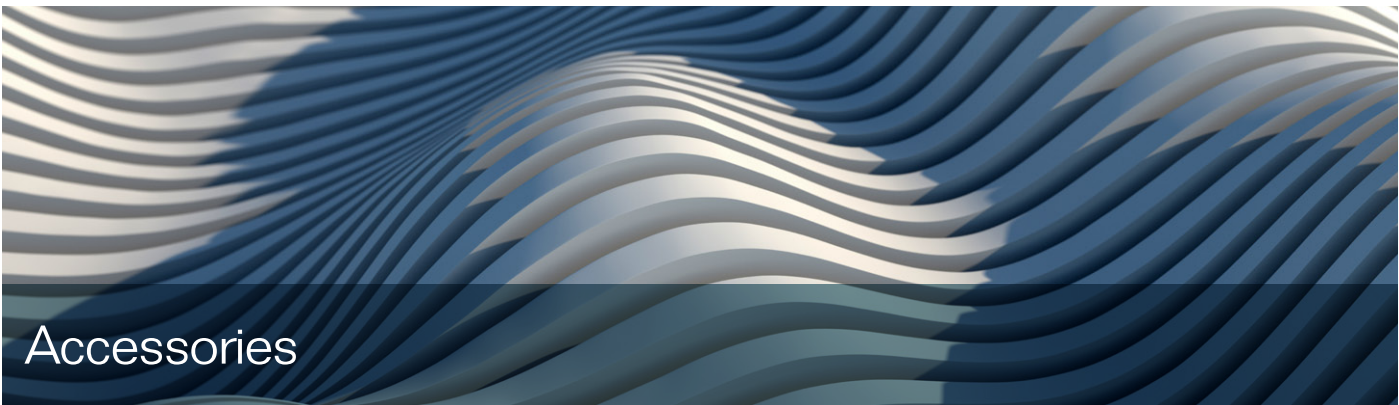

Accessories



Timpani

Birch



Timpani Birch hard **TR1**
 Timpani Birch medium **TR2**
 Timpani Birch soft **TR3**

Maple



Timpani maple staccato **TM0**
 Timpani maple hard **TM1**
 Timpani maple medium **TM2**
 Timpani maple soft **TM3**

Tonkin



Timpani tonkin staccato **TT0**
 Timpani tonkin hard **TT1**
 Timpani tonkin medium **TT2**
 Timpani tonkin soft **TT3**

Classic Signature



Bamboo cartwheel **CD1**
 Very bright and brilliant
 Hickory cartwheel **CD2**
 Bright
 Bamboo cartwheel **CD3**
 Warm, Sonorous
 Hickory cartwheel **CD4**
 Legato
 Bamboo ballstick **CD5**
 Dark, Mellow
 Hickory cartwheel **CD6**
 Soft, rich
 Bamboo ballstick **CD7**
 Dark, Sonorous, Rich
 Hickory wood stick **CD8**
 Extremely hard, Bright
 Hickory Flip stick **CD9**
 Extremely bright to general
 Hickory Chamois stick **CD10**
 Very brilliant to articulate



Scan this QR code for a full selection of Adams Mallets, or visit www.adams.nl/mallets/



701
Baroque Timpani Stand (Qty 1)



4MTST
Table for Mallets and Accessories



4MLTASLBB
Mallet Bag - Bogdan Bacanu



4STM1
Timpani Stool



4STM4A
Timpani Chair "Deluxe"



Gig Bag	Timpani Size/Model
4TRTNPARV20	20" Revolution Kettle
4TRTNPARV23	23" Revolution Kettle
4TRTNPARV26	26" Revolution Kettle
4TRTNPARV29	29" Revolution Kettle
4TRTNPARV32	32" Revolution Kettle
4TRTNPARVOET	Wheeled Base Bag (Qty 1)



PT100
Timpani Key



PBA02
Felt Timpani Muffler



Long Drop Cover	Timpani Size/Model
4TRHNPA20	20" Revolution
4TRHNPA23	23" Revolution
4TRHNPA26	26" Revolution
4TRHNPA29	29" Revolution
4TRHNPA32	32" Revolution



Head Cover	Timpani Size/Model
4TRAPPA20	20" Revolution
4TRAPPA23	23" Revolution
4TRAPPA26	26" Revolution
4TRAPPA29	29" Revolution
4TRAPPA32	32" Revolution



Flight Case	Timpani Size/Model
4TRFCPAPR20	20" Revolution
4TRFCPAPR23	23" Revolution
4TRFCPAPR26	26" Revolution
4TRFCPAPR29	29" Revolution
4TRFCPAPR32	32" Revolution



Adams Musical Instruments



Koning Willem I
Award

Winner biannual award
for best national
entrepreneurship

Aziëstraat 17-19
NL-6014 DA Ittervoort
The Netherlands

P.O. Box 3514
NL-6017 ZG Thorn
The Netherlands

Phone +31 (0)475 56 0710
Fax +31 (0)475 56 3328

export@adams.nl
www.adams-music.com



[www.facebook.com
/AdamsPercussion](http://www.facebook.com/AdamsPercussion)



[www.twitter.com
/AdamsPercussion](http://www.twitter.com/AdamsPercussion)

www.adams-music.com