

Vancore 

Productinformation

Marimbas



PSM 1010

5 octave C2 - C7 African Padauk

Made in Holland | Used Worldwide

Performing Standard Series

complete series of mallet instruments designed for the budget minded students, orchestras and ensembles. The frames of these instruments are manufactured using European Ashwood and high grade steel components. Height adjustment of these models can be executed manual very easily.

Performing Standard 1000 Series

These unique marimbas are featured with our newly designed ICS system (Integrated Cord Suspension). The suspension system is modular and functions as an Integrated part of an overall ergonomically and stylish designed instrument. The innovative frame has solid Ashwood endpieces and special designed steel layers. Precision lasercut bar support arms are angled to insure that each bar is supported exactly to the nodal point.

Bars

Material: Concert Quality African Padauk | Pterocarpus Soyauxii

As a perfect alternative for Honduran Rosewood, Vancore is using African Padauk as basic material for bar manufacturing. This African hardwood stands for a warm character and rich sustain. Through sizes of logs and availability of quarter sawn wood, the bars are representing a perfectly balanced marimba keyboard in performance and tonality.

Bar sizes: 71x27 | 65x27 | 58x25 | 53x25 | 48x25 | 44x23 | 40x21 mm

Height Adjustable Resonators

After years of research our R&D team has chosen rectangular bass resonators with produce optimum resonance and projection in lower registers. These resonators are tunable now! Our skilled tuning experts expertly tune each bar to exacting pitch standards.



Floating Bar Suspension | FBS

Most notable is the new Floating Bar Suspension System (FBS). This proprietary bar support system actually increases bar resonance by 20%! Precision laser cut bar support arms are angled to insure that each and every bar is supported exactly to the nodal point.



Integrated Rail System

Our designers created a new and highly innovative concept to avoid the common and major problem with layers. On top of that, the barsuspension and layer are integrated. One solution, one unique concept!



Endpieces

To realize stable and precise constructions, we use European Ashwood and high grade steel components. Rails and endpiece are very carefully designed to make that perfect match.



Height Adjustment

The height Adjustment of these models can be executed manual very easily.



Resonator Clamp System

Vancore resonators are individually hand tuned and Vancore resonators are individually hand tuned and assembled using an exclusive mounting system. This system eliminates every kind of rattle. Unlike other resonators, welded or riveted, our system employs minimal contact technology, this eliminates potential problems.

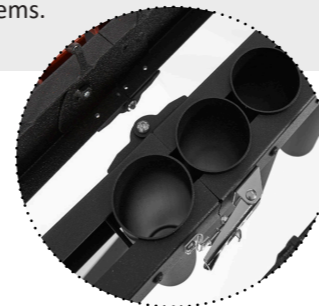

Casters

All stands are equipped with double rolled casters for easy operation. Carefully chosen casters come with high grade bearings and brakes.



A little different, but perfectly designed and engineered!

Vancore Custom classic 1000 series: designed for the budget minded students, orchestras and ensembles.

Boxnumber	Content	Box Sizes		Weight	
		CM	INCH	KG	LBS
Box 1 of 4	Frame/Resonators	143 x 84 x 45	56 x 33.0 x 17.7	58	127.87
Box 2 of 4	Stand/Bars	77 x 62 x 44	30.3 x 24.4 x 17.3	41.2	90.8
Box 3 of 4	Bas C-G	53 x 47 x 88	20.8 x 18.5 x 34.6	17.5	38.58
Box 4 of 4	Bas C#-G#	53 x 47 x 88	20.8 x 18.5 x 34.6	17.6	38.8

PACKED WEIGHT & DIMENSIONS



134.3 KG
296 LBS
 Instrument Weight



4
 Total number of boxes

WEIGHT & DIMENSIONS

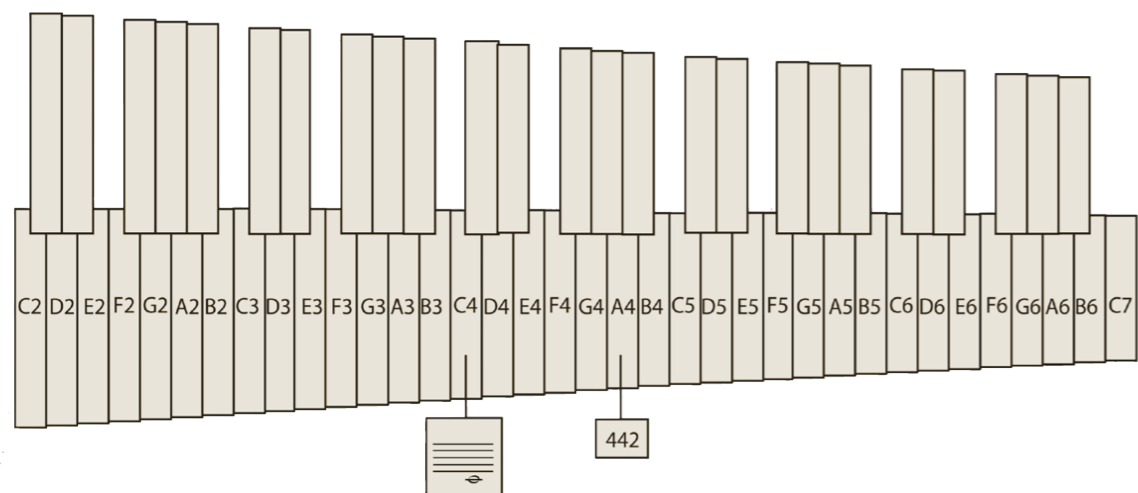
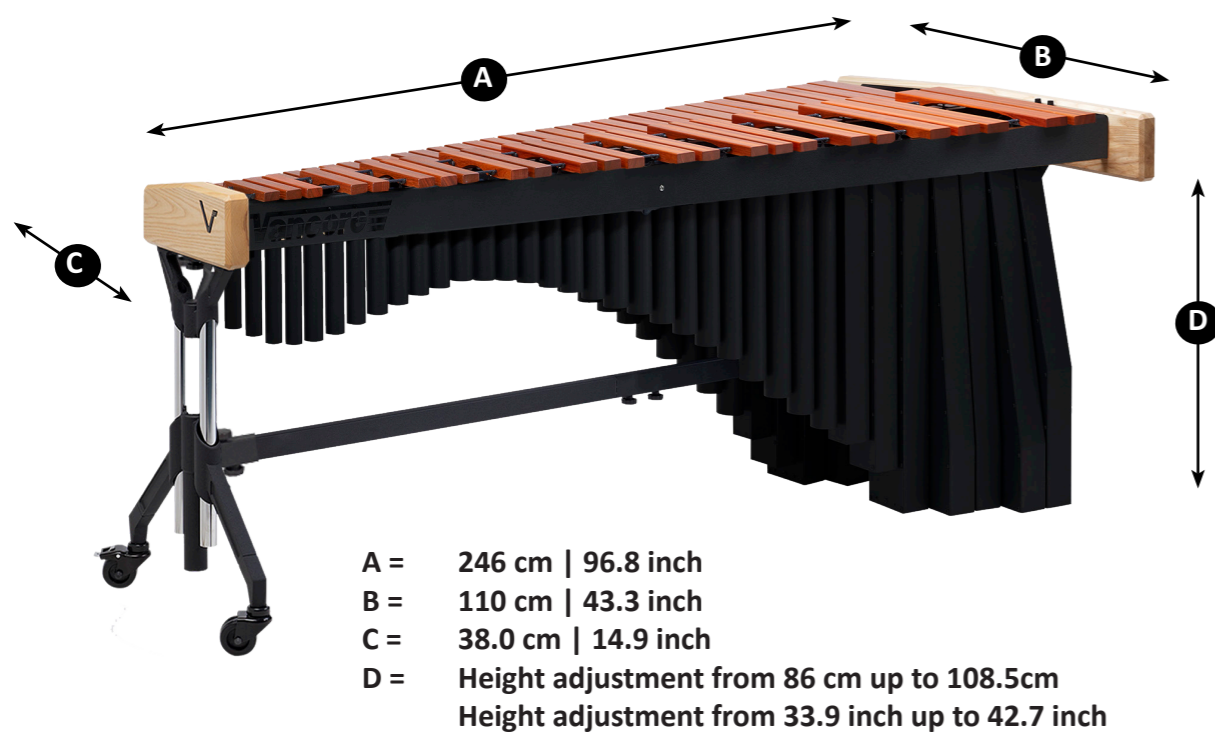

RANGE OVERVIEW

Vancore Nederland b.v.
 Tolhuswei 7a - 9
 8501 ZP JOURE - The Netherlands
 Tel: +31 513 415127
 Email: info@vancore.nl

www.vancore.com